

External Locking Assembly MAV 3012 light duty

rev. 0

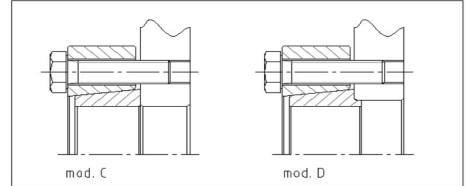
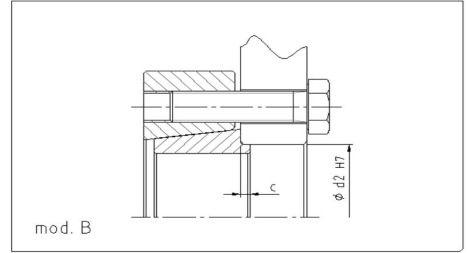
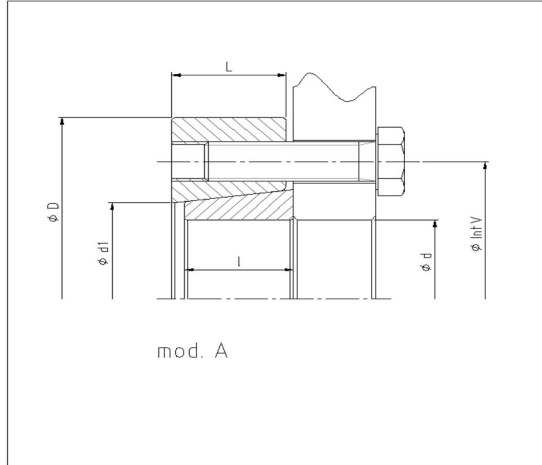

2-part design, 4 models available

Not self-locking

Screws ISO 4014/4017 grade 10.9

Screws & tapers greased with MoS₂

Shaft & hub contact surfaces: GREASE-FREE and DRY

Axial fixation of hub during tightening: yes

Max shaft tolerance: h9

Shaft / hub surface finish: $0.8 \leq Ra \leq 3.2 \mu m$

Transmissible torque is given by min. capacity

of shaft/lock.ass'y or hub/lock.ass'y contact surfaces

⁽¹⁾ screws length for model C and D

For narrow hub connections (ex. sprockets, brake discs)

For transmission of torque load only. For transmission of torque and bending loads, select MAV 3022 or 3023

Ma: screw tightening torque

Mt: transmissible torque

Example of order: MAV 3012 - 50 x 112 mod. A, B, C or D, hub width for mod. A and B

DIMENSIONS								SCREWS			PERFORMANCES	WEIGHT
d x D	L	IntV	l	d1	c	d2	No.	size ⁽¹⁾	Ma	Mt		
mm	mm	mm	mm	mm	mm	mm			Nm	Nm	kg	
11 x 39	10	25	9	13	2	12	3	M 6 x 18	12	20	0,1	
10 x 39	10	25	9	13	2	12	3	M 6 x 18	12	30		
9 x 39	10	25	9	13	2	12	3	M 6 x 18	12	24		
13 x 44	13	28	12	16	2	14	3	M 6 x 20	12	87	0,1	
12 x 44	13	28	12	16	2	14	3	M 6 x 20	12	87		
11 x 44	13	28	12	16	2	14	3	M 6 x 20	12	87		
16 x 52	15	36	14	21	2	18	3	M 8 x 25	30	151	0,2	
15 x 52	15	36	14	21	2	18	3	M 8 x 25	30	133		
14 x 52	15	36	14	21	2	18	3	M 8 x 25	30	116		
20 x 60	17	42	16	26	2	22	3	M 8 x 30	30	250	0	
18 x 60	17	42	16	26	2	22	3	M 8 x 30	30	250		
16 x 60	17	42	16	26	2	22	3	M 8 x 30	30	250		
25 x 66	19	48	18	32	2	27	5	M 8 x 30	30	429	0	
22 x 66	19	48	18	32	2	27	5	M 8 x 30	30	332		
20 x 66	19	48	18	32	2	27	5	M 8 x 30	30	275		
30 x 76	21	56	20	38	2	32	6	M 8 x 35	30	672	1	
28 x 76	21	56	20	38	2	32	6	M 8 x 35	30	660		
25 x 76	21	56	20	38	2	32	6	M 8 x 35	30	526		
40 x 96	25	70	24	47	3	43	6	M 10 x 35	59	1.340	1	
35 x 96	25	70	24	47	3	43	6	M 10 x 35	59	1.310		
30 x 96	25	70	24	47	3	43	6	M 10 x 35	59	1.120		
50 x 112	30	84	29	58	3	53	7	M 12 x 45	100	2.670	2	
45 x 112	30	84	29	58	3	53	7	M 12 x 45	100	2.540		
40 x 112	30	84	29	58	3	53	7	M 12 x 45	100	2.010		
60 x 120	34	94	32	66	3	63	9	M 12 x 50	100	3.690	2	
55 x 120	34	94	32	66	3	63	9	M 12 x 50	100	3.100		
50 x 120	34	94	32	66	3	63	9	M 12 x 50	100	2.870		
70 x 148	40	112	38	79	4	74	8	M 16 x 60	250	6.930	4	
65 x 148	40	112	38	79	4	74	8	M 16 x 60	250	5.980		
60 x 148	40	112	38	79	4	74	8	M 16 x 60	250	5.090		
80 x 170	44	130	42	94	4	84	9	M 16 x 65	250	10.120	6	
75 x 170	44	130	42	94	4	84	9	M 16 x 65	250	9.060		
70 x 170	44	130	42	94	4	84	9	M 16 x 65	250	7.890		
90 x 185	50	144	48	104	4	94	12	M 16 x 70	250	13.600	8	
85 x 185	50	144	48	104	4	94	12	M 16 x 70	250	12.100		
80 x 185	50	144	48	104	4	94	12	M 16 x 70	250	11.500		
100 x 197	54	156	52	114	4	104	14	M 16 x 75	250	18.600	10	
95 x 197	54	156	52	114	4	104	14	M 16 x 75	250	18.300		
90 x 197	54	156	52	114	4	104	14	M 16 x 75	250	18.100		