



# DR 120R



## DATA SHEET



rev. 1.7  
12 May 2021

## Compact stand alone PLC

- Fixing system on din rail
- Compact PLC Modbus RTU protocol compliant
- Contact programming with Ladder language

Kernel Sistemi  
Kernel Sistemi s.r.l. , via Vignolese n. 1138  
41126 Modena - ITALY  
Tel. 059 469 978 - Fax 059 468 874  
[www.kernelgroup.it](http://www.kernelgroup.it)

## INDEX

<b>1</b>	<b>HARDWARE CHARACTERISTICS.....</b>	<b>3</b>
1.1	Electric Characteristics.....	3
1.2	Mechanics Characteristics.....	4
1.3	I/O Connections.....	4
<b>2</b>	<b>SOFTWARE CHARACTERISTICS.....</b>	<b>5</b>
<b>3</b>	<b>CONTACTS.....</b>	<b>6</b>

# 1 HARDWARE CHARACTERISTICS

This chapter describes the hardware characteristics of DR\_120R :

## 1.1 Electric Characteristics

ELECTRIC CHARACTERISTICS	
Power supply voltage	24 Vdc +/- 10 %
Maximum Permitted Power Supply	27 Vdc
Current Consumption	Under 150 mA without loads [Power Supply = 24 Vdc]
Microprocessor	ARM STM 100
Program Memory	64 KByte
Pages Memory	64 KByte
EEProm	64 KByte
Cycle Time	Programmable (min 1 msec.)
Digital Inputs	10 digital inputs PNP 24 Volts with programmable anti-noise filter (value 1 ... 16)
Analog Inputs	2 analog inputs with 12 bits resolution [0 ... 4095] for voltage (0 ... 10 V) or current (0 ... 20 mA)
Digital Outputs	6 relè outputs 24 Vdc
Analog Outputs	2 analog outputs 0 ... 10 V with 12 bit resolution [0 ... 4095]
Plugged RAM	42 words copied automatically into plugged RAM any 100 msec
RTC	Internal Real time clock buffered by a rechargeable battery
Current analog input Impedance	250 Ohm
Voltage analog input Impedance	10 KOhm
Serial Lines	<p>2 serial lines (COM 1, COM 2) :</p> <p><b>COM 1</b> : It's in RS 232 ; it can be used with many different standard communication protocols for connect other devices (thermoregulators, inverters or network connection) besides it's used for upload applications or operative system</p> <p><b>COM 2</b> : It's in RS 485 mode and can be used with many different standard communication protocols for connect other devices (thermoregulators, inverters or network connection)</p>
ETH	No
Mini USB	No
USB Pendrive	No
Other hardware supports	<ul style="list-style-type: none"> <li>• Three status indicator leds (yellow, red, green): Communication, Alarm, and RUN/STOP</li> <li>• Internal RUN/STOP PLC button</li> <li>• Internal trimmer usable as analog input for the hardware management of a parameter</li> </ul>

### 1.2 Mechanics Characteristics

MECHANICS CHARACTERISTICS	
Temperature Range	From -10 ^C to +70^C
Humidity Range	From 10 % to 90 % (non-condensing)
Operating Atmosphere	Without corrosive gas
Noise Immunity	According to rules in force
Fixing System	On din rail
Weight	n.d.
Keyboard	No keyboard
Display	No Display
Size	Front View 106x90 ; Depth 58 mm

58

106

**SIDE VIEW**

90

### 1.3 I/O Connections

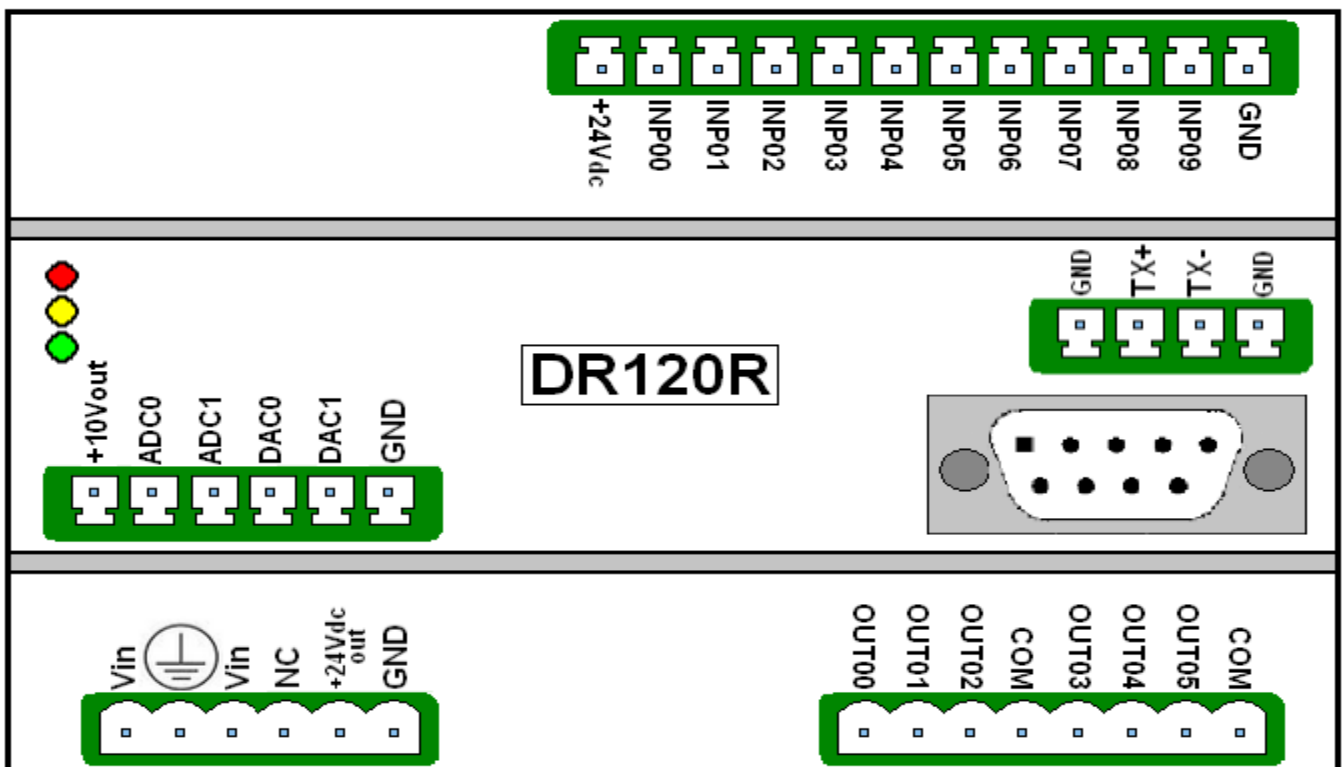

## 2 SOFTWARE CHARACTERISTICS

SOFTWARE CHARACTERISTICS	
Programming Languages	AWL / Ladder
Timers	<ul style="list-style-type: none"> <li>- 64 timers at 16 bit with 1/100 sec resolution.</li> </ul> Timers are configurable like : excitation delay, disexcitation delay or one pulse <ul style="list-style-type: none"> <li>- 8 timers "free running" with a resolution of 1 msec, individually activated with system flag</li> </ul>
Counters	64 counters at 16 bit configurable like increase or decrease
Memory	8192 DATA MEMORY 16 bit general purpose, some with special meaning, numbered from DATA.00 to DATA.8191
FLAG	256
SYS	233
RTF	1536 Retentive Flags
NVDATA	42 Non-Volatile DATA
Developed Functions	<ul style="list-style-type: none"> <li>- Weekly Programmer</li> <li>- Recipes Management</li> <li>- P.I.D. Temperature Regulator</li> <li>...</li> </ul>
Memory area check in real time mode on data table ( Debug )	Yes
Ladder's subroutines Import / Export	Yes
Contact and variable check in real time mode on ladder ( Debug Online )	Yes



## 3 CONTACTS

### GENERAL

Tel: 059 469978  
website: [www.kernelgroup.it](http://www.kernelgroup.it)  
e-mail: [info@kernelgroup.it](mailto:info@kernelgroup.it)

### COMMERCIAL

Sig.ra Linda Mammi  
Tel: 059 469978 Int. 207  
e-mail: [sales@kernelgroup.it](mailto:sales@kernelgroup.it)  
Skype: mammi.kernel

### ADMINISTRATION

Sig.ra Paola Morandi  
Tel: 059 469978 Int. 201  
e-mail: [amministrazione@kernelgroup.it](mailto:amministrazione@kernelgroup.it)  
Skype: morandi.kernel

### PURCHASING and PRODUCTION

Sig. Stefano Catuogno  
Tel: 059 469978 Int. 204  
e-mail: [produzione@kernelgroup.it](mailto:produzione@kernelgroup.it)  
Skype: catuogno.kernel

### TECHNICAL OFFICE

Sig. Alessandro Muratori  
Tel: 059 469978 Int. 205  
e-mail: [alessandro.muratori@kernelgroup.it](mailto:alessandro.muratori@kernelgroup.it)  
Skype: muratori.kernel

Support  
Tel: 059 469978 Int. 209  
e-mail: [support@kernelgroup.it](mailto:support@kernelgroup.it)  
Skype: support.kernel

Sig. Morisi Luca  
e-mail: [luca.morisi@kernelgroup.it](mailto:luca.morisi@kernelgroup.it)  
Skype: morisi.kernel

Kernel Sistemi s.r.l. , via Vignolese n. 1138  
41126 Modena - ITALY  
Tel. 059 469 978 - Fax 059 468 874  
[www.kernelgroup.it](http://www.kernelgroup.it)